

ALL-WHEEL DRIVE LIGHT COMMERCIAL GAZ VEHICLES

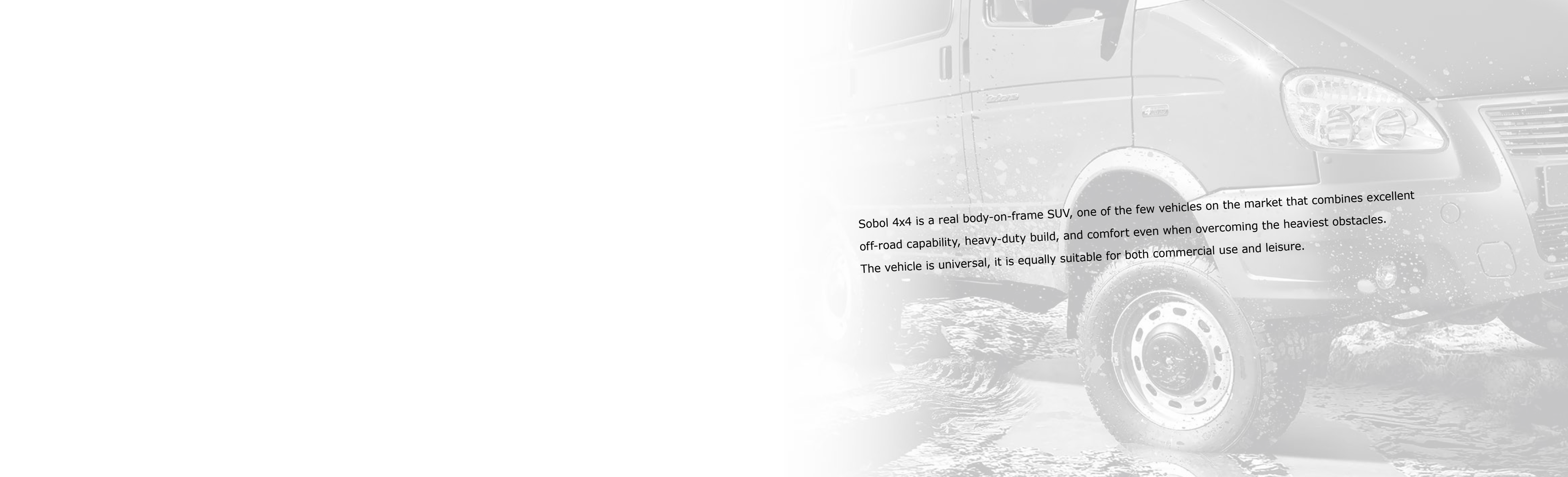



Sobol 4x4 is a real body-on-frame SUV, one of the few vehicles on the market that combines excellent off-road capability, heavy-duty build, and comfort even when overcoming the heaviest obstacles. The vehicle is universal, it is equally suitable for both commercial use and leisure.



THE POWER OF FREEDOM

Sobol 4WD gives you comfort of driving on highways or dirt roads using only the rear drive.

Due to its soft suspension, Sobol performs confidently even on rough roads, easily dealing with potholes.

However, off-roading is where Sobol 4WD really shines. The vehicle simply transforms and gives its owner a huge degree of freedom when it comes to choosing a driving direction. High road clearance, continuous sprung axles, connected all-wheel drive, reduction drive, huge suspension travel, powerful drive shafts, and a locking rear differential allow you to drive through mud, overcome gullies, climb the rocks, and get out of the traps. The vehicle moves through snow and sand like an icebreaker, making its track.

Of course, reasonable precautions never hurt. No wonder they came up with a saying: "The better off-road capability your vehicle has, the further you have to walk to get a tractor to pull you out." Sobol off-road capability makes this saying so true.

CONNECTED ALL-WHEEL DRIVE

The Part-Time system of connected all-wheel drive is a fairly simple mechanism that is reliable in extreme situations and easily repairable. The vehicle becomes universal for trips around the city and beyond, it provides good off-road capability in conditions of loose and deformable soils. The system allows to save fuel when driving on a dry flat road using the rear drive, connecting the front axle only for the real off-road sections.



CROSS-SECTIONAL OFF-ROAD CAPABILITY

Along with the small wheelbase, ground clearance (250 mm) provides a small radius of longitudinal off-road capability, which positively affects the ability of the vehicle to overcome complex sections of the road with an uneven profile without contact of the body and transmission elements with the ground. Wide approach/departure angles guarantee no contact when overcoming obstacles and protection of bumpers from damage.



GROUND CLEARANCE

Road clearance up to 205 mm ensures excellent off-road capability and allows to drive without noticing obstacles — starting with speed bumps and curbs within the city limits and ending with deep winter or fieldtracks, sand, and fallen trees in off-road conditions.



LONG SUSPENSION TRAVEL

This allows the wheels to stay on the ground on uneven surfaces and, accordingly, the vehicle can move in the right direction.





REDUCTION DRIVE

allows the vehicle to move at low speeds at high rpms and engine power, that is, it increases the torque on the wheels when overcoming obstacles — off-road, black ice, ford.



TURNING RADIUS 6.0 m

A small wheelbase along with a large angle of directive wheels rotation provides the vehicle with excellent maneuverability (small turning radius) in constrained urban and suburban conditions (forest belt, track, winding road, etc.).



REAR LOCKING DIFFERENTIAL

provides a significant improvement in the vehicle's off-road performance on slippery road sections or deformable soil and maximum wheel efficiency when locked: the torsion torque is sent to the running wheels with a 50/50 distribution.

OFF-ROAD TIRES 225/75R16

Universal and heavy-duty tires with high flotation and wear resistance when used on asphalt, dirt, and sand and gravel roads, in off-road and ford conditions.

RELIABLE BASE

The simplicity of design and good maintainability of GAZ 4WD vehicles are combined with the wide use of assemblies and components from the world's leading manufacturers. Braking system with vacuum boosters, rear differential lock, gearbox bearings synchronizers, clutch, and drive shafts with CVUJ provide the vehicle with high reliability and good consumer characteristics. The body-on-frame design of Sobol 4WD allows to evenly distribute loads when driving through rough terrain and provides a high degree of rigidity, reliability, and heavy-duty performance of the transmission

Sobol body parts that are most exposed to the aggressive external environment are made of galvanized steel. Cathaphoresis priming of the body and frame of the vehicle provides excellent anti-corrosion characteristics.

Alloy wheels and tinted windows are not included into the base configuration.





BODY-ON-FRAME DESIGN

- Preferable option, it provides an advantage over analogues with a monocoque body.
- It has a threefold margin of safety, which allows the loaded vehicle to confidently move along a bumpy road, providing endurance under alternating loads.
- Provides better maintainability.
- Helps reduce noise and vibration from the engine.



GEARBOX

5-speed manual transmission with primary and secondary shaft bearings, synchronizers of 1st and 2nd gearboxes, and cuffs provides the following characteristics:

- high assembly reliability;
- no leaks through gearbox cuffs;
- low noise level in the gearbox;
- optimal effort placed on the gearshift when shifting gears.

REAR AXLE

The design of the rear axle with ring lockers with a reduced gear ratio, multi-rim cuffs, ground teeth of final drive pinions provides reduced fuel consumption, no fluid leaks, improved manufacturing quality, and reliability.



SACHS SUSPENSION BUMPERS

- Smooth ride and improved handling.
- High active safety.
- Heavy-duty construction.

SUSPENSION SPRINGS

Due to front springs made of materials with increased physical and mechanical properties of a medium-duty vehicle, insertion of gaskets between sheets, and changes in the hardening of the surface layer and the painting technologies, service life of springs are doubled, vehicle handling is improved, and active safety of the vehicle is increased.

SACHS CLUTCH AND CLUTCH LINKAGE

- Optimal effort placed on the clutch pedal.
- Heavy-duty construction.
- Reduced noise and vibration in the transmission.
- No jerks when starting to drive.
- No leaks in the clutch hydraulic gear.
- Simple assembly/disassembly.

VACUUM BOOSTER

- High reliability of the brake system drive.
- Less effort when pressing on the brake pedal.
- Progressive characteristic of the module.
- Optimal response time, high active safety of the vehicle.
- Optimal weight of the new module.

COOLING SYSTEM

Two-way radiator with increased heat output ensures high efficiency of the cooling system in all driving modes and no leaks during operation of the vehicle.

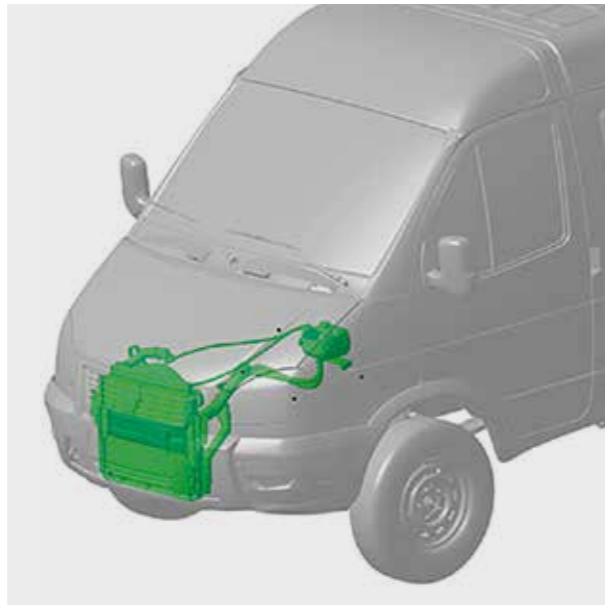

AIR INTAKE AND FUEL INJECTION SYSTEMS

These systems with polyamide fuel lines ensure no deformation of air ducts during operation and reduction of internal noise.

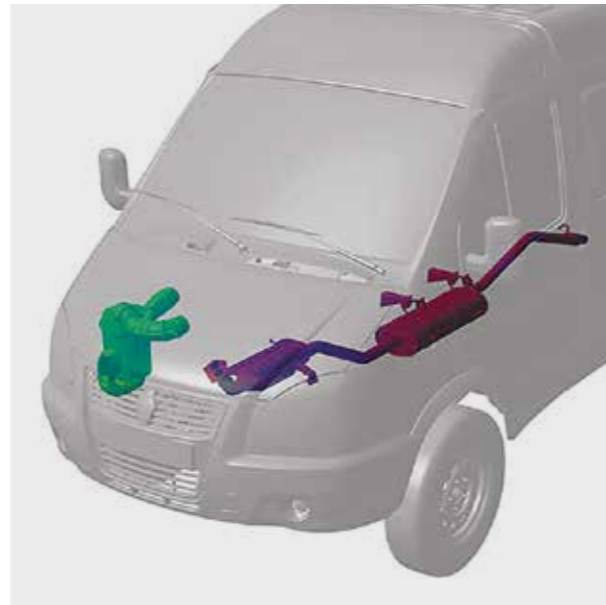



DRIVE SHAFT

Drive shafts with CVUJ allows to reduce vibrations, eliminate uneven drive shaft rotation, reduce power losses in drive gear, as well as wear of gears and transmission shafts, providing increased reliability and durability of the structure.



STEERING CONTROL WITH HPS

Non-serviceable steering shaft increases reliability and service life of the assembly, leads to improved handling, steering feedback, increased active safety of the vehicle, no leaks and noise during operation of the vehicle.



CORROSION RESISTANCE

- 47 parts with double-sided galvanizing mounted on the car bottom subject to the maximum corrosive effects.
- Galvanized hinges of rear swing doors with fastening from the inside of the body.
- Cathaphoresis priming of parts within a frame: crossbar of the engine rear support, shock absorber bracket, cap pieces of front and rear springs, rear draft hooks.
- Sheet-by-sheet two-layer painting and additional processing of springs using anti-gravel materials.
- Surface treatment of drive axles and shaft axles using anti-gravel materials.



Body galvanizing scheme



SAFETY EXPERT

All design elements of GAZ 4WD vehicles are designed to provide the maximum level of safety for the driver and passengers.

Due to the short hood configuration, the vehicle features a vital crumple zone.

High clearance not only facilitates navigation through city traffic jams, but also provides excellent visibility and convenience of parking in any conditions coupled with large two-section power heated side-view mirrors.

BRAKING SYSTEM

Front wheels disk brakes and vacuum booster provide a minimum braking distance among domestic all-wheel drive vehicles, emergency braking, and no wobbling when braking.

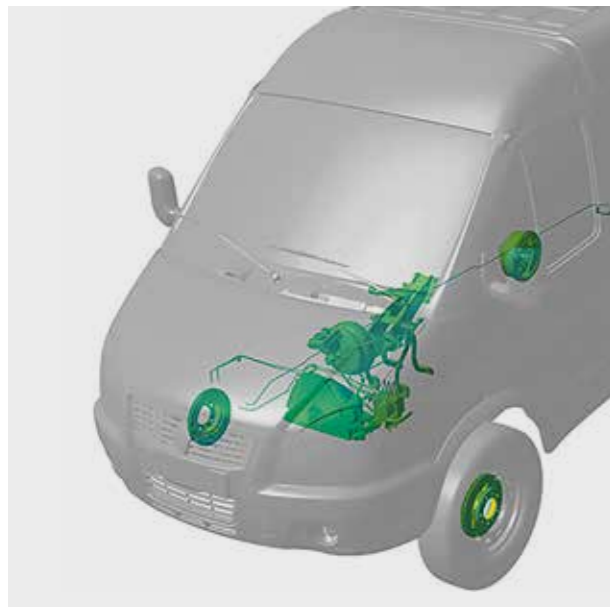

COLLAPSIBLE STEERING COLUMN AND STEERING WHEEL

Collapsible system is equipped with HPS in standard configuration. It has optimal geometric parameters.



REAR-VIEW MIRRORS

with electric heating and wide-angle section in standard configuration provide maximum visibility from the driver's and front passenger seats, eliminating blind spots.



WIND SCREEN

The windscreen area of 1.5 square meters provides maximum visibility of the road from the driver's seat, eliminating blind spots. Increased clamping force, the number of movements of wiper blades, and a wiper gear motor with increased power and reliability ensure high cleaning efficiency of the windscreen in any conditions.

SHORT HOOD CONFIGURATION

Provides a crumple zone in case of a front collision, as well as arrangement of the engine and other systems outside the cabin.

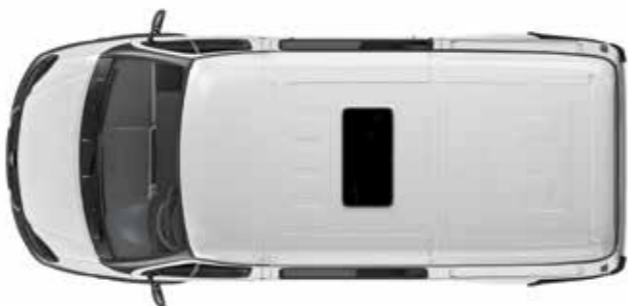



SEATS

All seats are equipped with seat belts, which are located in the direction of travel, featuring a comfortable backrest angle.



ABS

ABS is a key component of the vehicle safety system. It comes as standard equipment of buses or can be installed optionally. Features stability and handling.

EFFICIENT LIGHTING OF A ROAD

Ability to have high beams on at the same time with low beams provides maximum visibility of the road from the driver's seat.



REAR LOCKING DIFFERENTIAL

allows the driver to rigidly connect both rear wheels and transfer all the torque from the rear axle gear wheel to the hubs of the axle and allows for the rotation of the wheels at different frequencies when necessary.

- Significantly improves off-road capability in difficult-sections of the road when slippery or deformable soil.
- Is installed according to factory standards.
- Does not affect the handling in normal mode.
- Provides a minimum investment for increased off-road performance.
- Has a simple, reliable, and durable construction — an electromagnetic control mechanism.
- Completely interchangeable with the old assembly — fits ideally into the rear axle housing of GAZelle and Sobol.



TRAVEL WITH COMFORT

Excellent off-road capability coupled with a high level of comfort makes the vehicle universal for any task. A powerful engine allows to easily withstand the rhythm of the urban flow. Due to little efforts required to turn the steering wheel and press on pedals, good steering feedback, adjustable steering column in two planes, and a comfortable driver's seat, the driver will not get tired even during long journeys. A regular temperature booster and two heaters provide the comfortable temperature in the cabin, even in cold weather.

An important distinctive feature of Sobol is its huge interior space. This volume is not available for any vehicle of this class. It is possible to walk inside the saloon, slightly bent your head, move from the front row of seats to the rear one on the go. It is possible to accommodate up to 900 kg of cargo in the cargo compartment.

If you buy Sobol for recreation rather than commercial use, due to its spacious interior you can easily turn it into an autonomous travel vehicle.





INTERIOR

Comfortable driver's seat: collapsible steering column is adjustable to get the best angle, inclination, and height, HPS comes in standard configuration, collapsible steering wheel of the optimal diameter and thickness, option control buttons can be installed.

Safe and convenient dashboard features all the necessary control systems, has a convenient configuration and a well-read gauges.

The front axle connection signal is located on the dashboard. There's little effort when pressing on the clutch pedal. The front axle connection lever can be easily switched from the driver's seat.

Driver's seat can be adjusted in longitudinal direction and inclination angle. Convenient arrangement of all seats, a sufficient amount of free space. Wide side door.

BODY LAYOUT

All control systems are placed outside the cabin, which ensures no noise, odor, or fuel products and additional heating from the engine. The washer tank is located under the hood and has a combined control with a wiper drive. The vehicle is simple to service, since all systems are located under the hood.

HEATING AND VENTILATION SYSTEM

The system feature air distribution functions in the cabin and additional heater in vehicles with a second row of seats, ensures that the cabin, interior, and body wouldn't overheat or freeze. Air conditioning comes in standard configuration. The system provides electronic control of the air conditioning system from the dashboard. Short-circuit loop is arranged through the heater tap to increase the coolant temperature in the winter period. A high-performance heater and a noiseless, multi-stage fan are used.

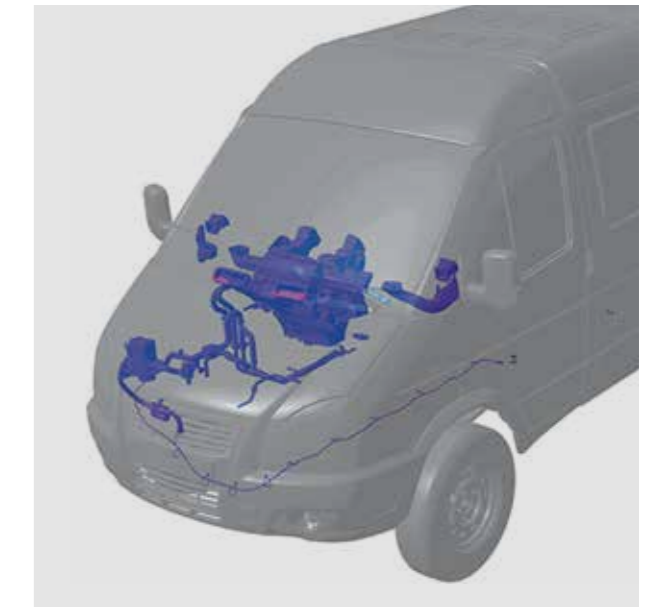
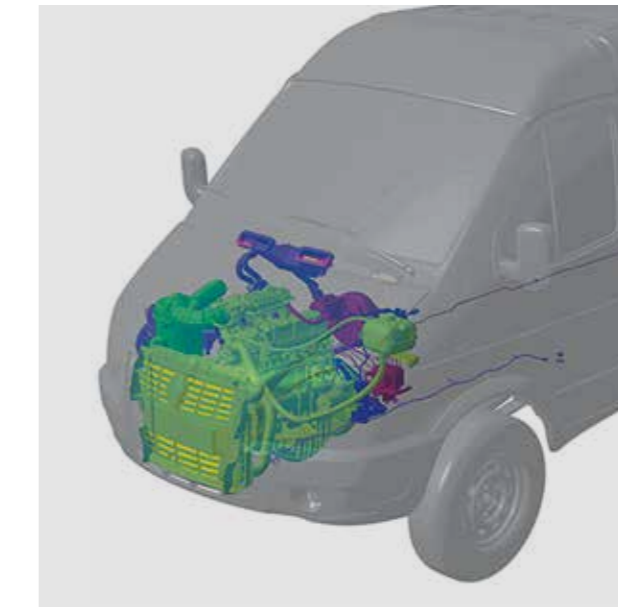

**SOBOL 4WD
GAZ-23107**

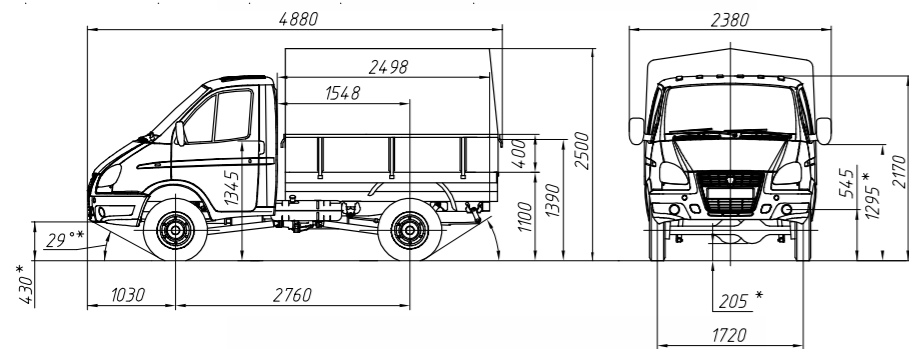

**GAZelle Business 4WD
GAZ-33027**

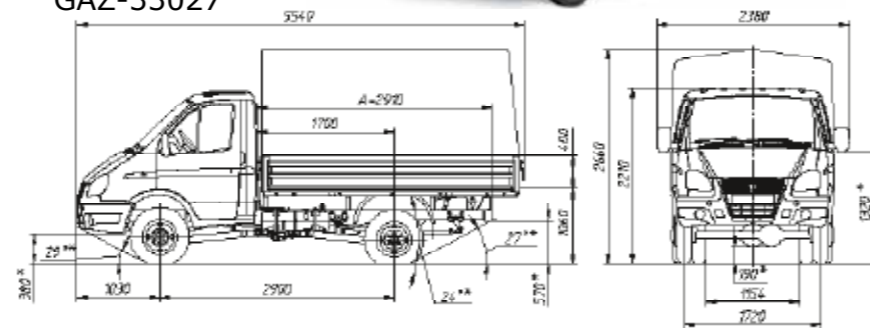

**SOBOL 4WD
GAZ-231073**

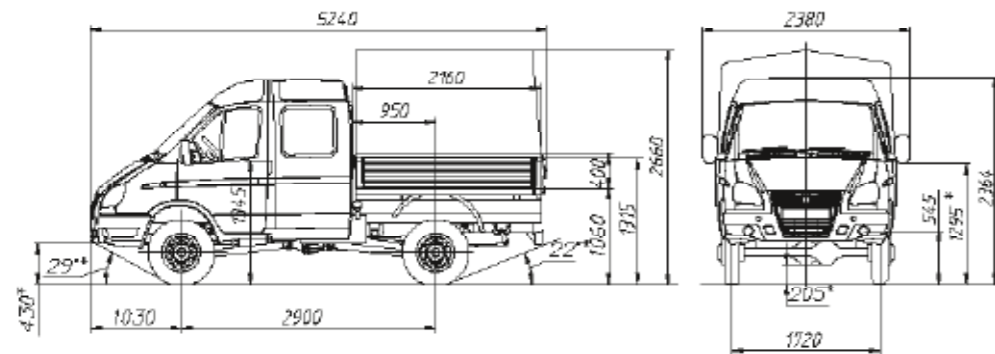

**GAZelle Business 4WD
GAZ-330273**

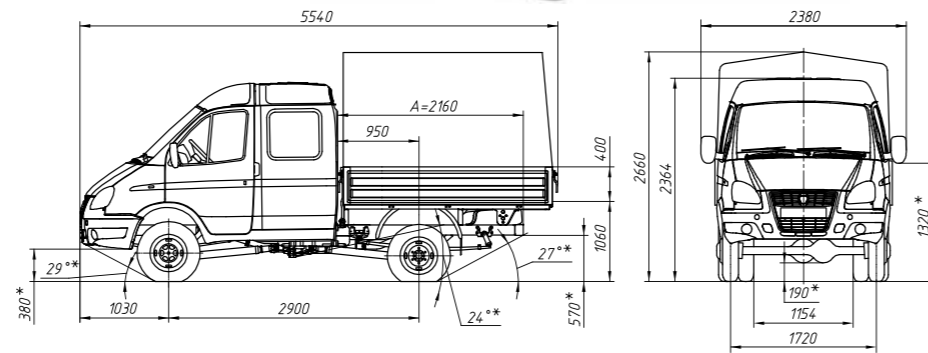

**SOBOL 4WD
GAZ-27527**

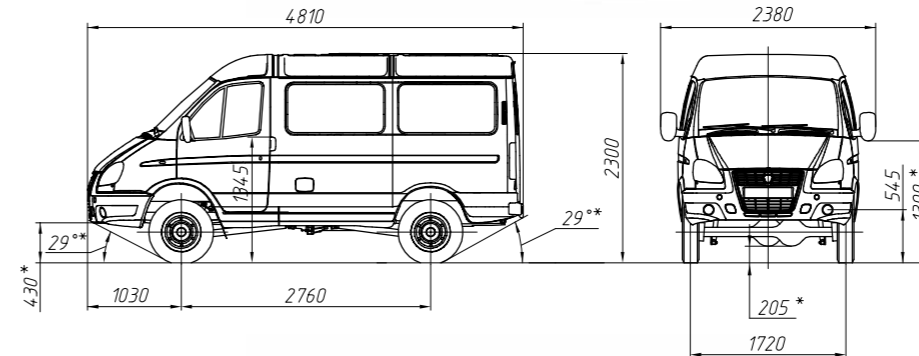

**GAZelle Business 4WD
GAZ-27057**

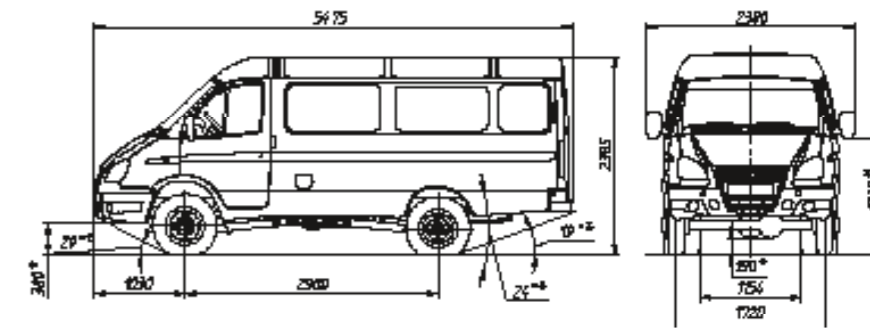

**SOBOL 4WD
GAZ-27527 (6+1)**

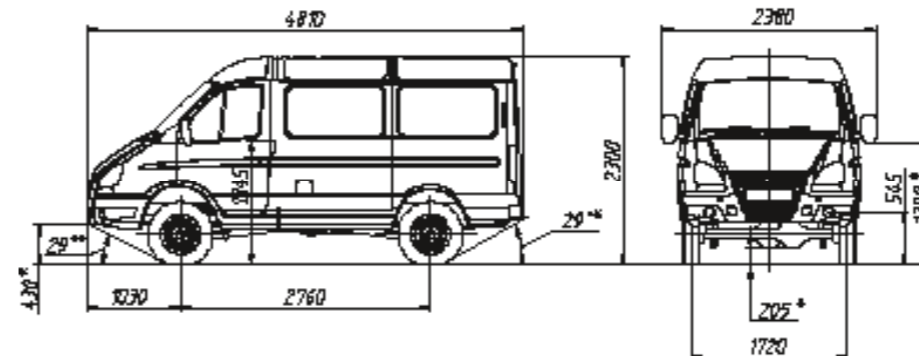

**GAZelle Business 4WD
GAZ-27057 (6+1)**

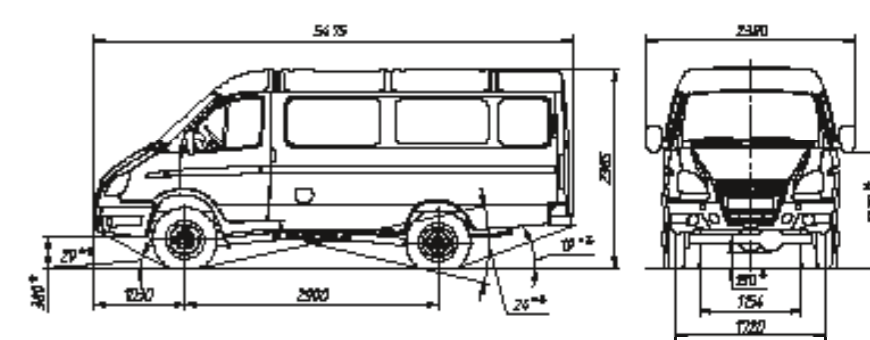

**SOBOL 4WD
GAZ-22177 (6+1)**

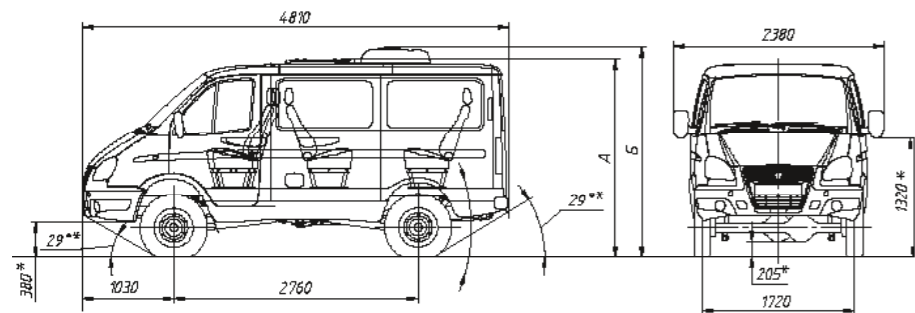

**GAZelle Business 4WD
GAZ-32217 (8+1)**

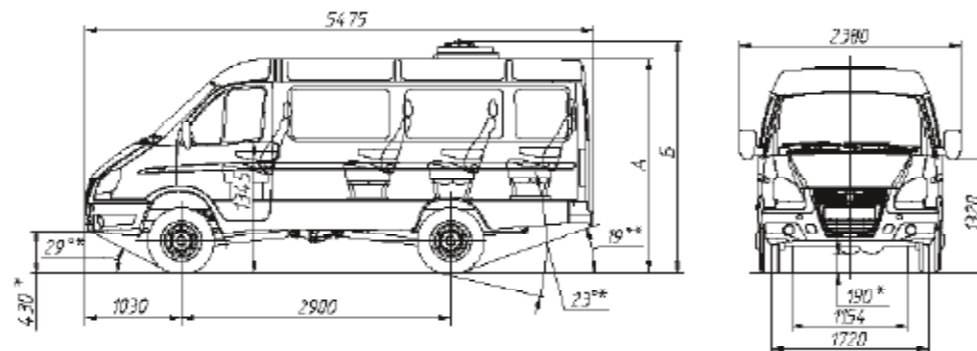

**SOBOL 4WD
GAZ-221717 (6+1)**

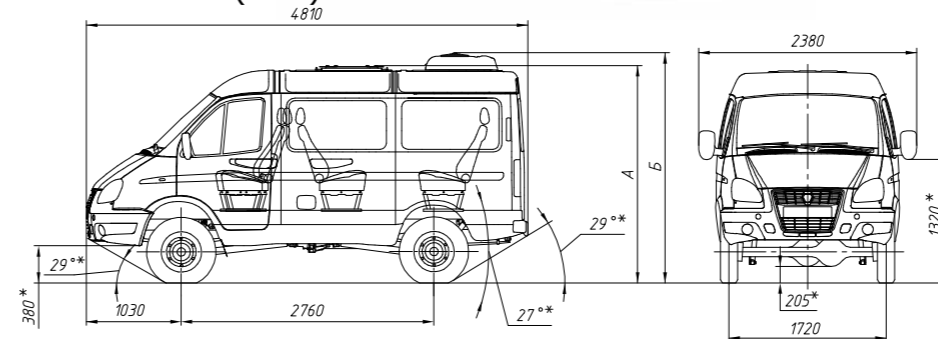

**GAZelle Business 4WD
GAZ-32217 (13+1)**

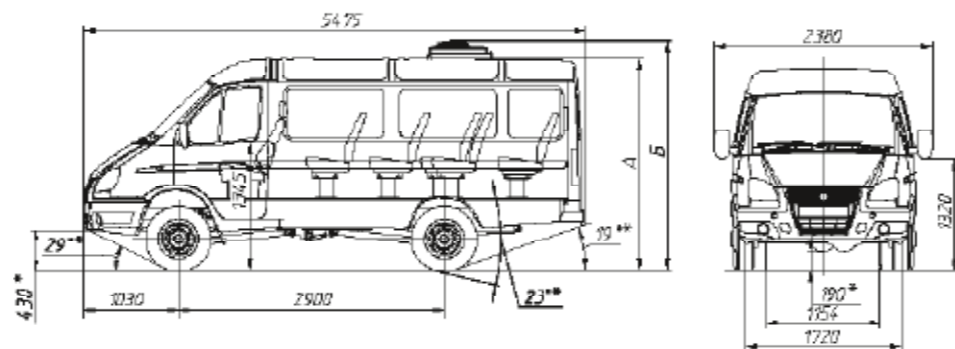

**SOBOL 4WD
GAZ-221717 (10+1)**

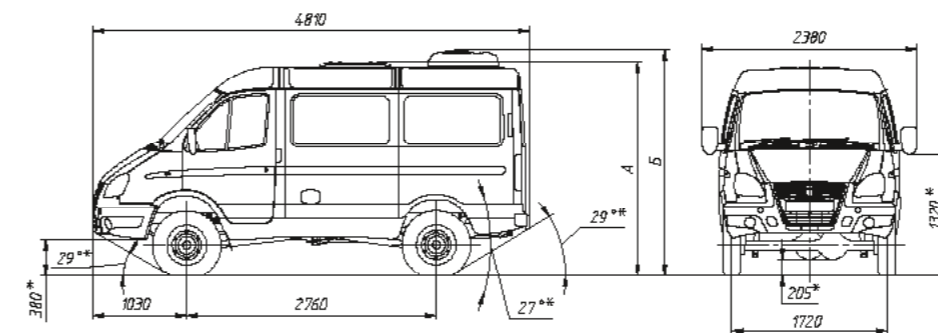

TECHNICAL SPECIFICATIONS

	Sobol 4WD							GAZelle Business 4WD						
	Dropside truck		Panel van			Bus		Dropside truck		Panel van			Bus	
	23107	231073	27527	27527	221717	22177	33027	330273	27057	27057	32217	322173		
GENERAL DATA														
Wheel formula	4x4	4x4	4x4	4x4	4x4	4x4	4x4	4x4	4x4	4x4	4x4	4x4	4x4	
Number of seats (driver + passengers)	1+2	1+5	1+2	1+6	1+6	1+10	1+6	1+2	1+5	1+2	1+6	1+8	1+12	
Minimum ground clearance under the front and rear axle housing of the fully loaded vehicle, mm	205	205	205	205	205	205	205	190	190	190	190	190	190	
Gross weight, kg	3000	3120	3000	3000	3030	3250	3005	3500	3500	3500	3500	3320-3350	3630-3650	
Curb weight, kg	2065-2125	2235	2210-2270	2320-2380	2480-2510	2420-2450	2465-2495	2130-2190	2260-2320	2290-2350	2420-2480	2620-2650	2580-2610	
Axle load of the fully loaded vehicle (front/rear axle), kg	1520/1480	1575/1545	1530/1470	1645/1355	1520/1510	1630/1630	1505/1500	1440/2060	1500/2000	1500/2000	1500/2000	1300/2020	1415/2215	
Minimum turning radius of the outer front wheel, m	6.0	6.5	6.0	6.0	6.0	6.0	6.0	7.5	7.5	7.5	7.5	7.5	7.5	
Volume of cargo compartment, m ³	6.9	6	6.8	3.7	-	-	-	9.8	7.5	9	6	-	-	
Maximum driving gradient of the fully loaded vehicle, %	30	30	30	30	30	30	30	30	30	30	30	30	30	
Max speed of the vehicle on the level stretch of high road, km/h	115	115	115	115	115	115	115	120	120	120	120	120	120	
Reference fuel consumption at a constant speed of 60/80 km/h, l/100 km	7.8/11.2	7.8/12	7.8/11.2	7.8/11.2	7.8/11.2	7.8/11.2	7.8/11.2	9.8/11.3	9.8/11.3	9.8/11.3	9.8/11.3	9.8/11.3	9.8/11.3	

	Sobol 4WD						GAZelle Business 4WD					
	Dropside truck		Panel van		Bus		Dropside truck		Panel van		Bus	
	23107	231073	27527	27527	221717	22177	33027	330273	27057	27057	32217	322173
REAR WHEEL TIRE CONFIGURATION	Single-tire						Double-tire					
Doors	2: two swing cabin doors	2: two swing cabin doors	5: two swing cabin doors, one sliding side door, two rear swing doors	5: two swing cabin doors, one sliding side door, two rear swing doors	5: two swing cabin doors, one sliding side door, two rear swing doors	4: two swing cabin doors, one sliding side door, one rear door opening upwards	2: two swing cabin doors	2: two swing cabin doors	5: two swing cabin doors, one sliding side door, two rear swing doors	5: two swing cabin doors, one sliding side door, two rear swing doors	5: two swing cabin doors, one sliding side door, two rear swing doors	5: two swing cabin doors, one sliding side door, two rear swing doors
Transmission	Single-disk, dry, with hydraulic drive						Single-disk, dry, with hydraulic drive					
Clutch	Mechanical, five-speed, with all gears being synchronized						Mechanical, five-speed, with all gears being synchronized					
Gearbox	Part-time, mechanical, with two stages: high (i=1.07) and low (i=1.86)						Part-time, mechanical, with two stages: high (i=1.07) and low (i=1.86)					
Transfer gearbox	Three shafts with six constant-velocity joints						Three shafts with six constant-velocity joints					
Cardan drive	Final drive: hypoid, gear ratio – 4.566 Differential: conical, gear Half axles: fully floating						Final drive: hypoid, gear ratio – 4.566 Differential: conical, gear Axle swivels: with different-velocity universal joints					
Front axle	Final drive: hypoid, gear ratio – 4.566 Differential: bevel, gear-type						Final drive: hypoid, gear ratio – 4.566 Differential: bevel, gear-type					
Rear axle	Fully floating						No					
Half axles	Fully floating						No					
RUNNING GEAR												
Wheels	Steel, stamped, disc, with 6JxH2 solid rim						Steel, stamped, disc, with 2 5Jx16H2 solid rim					
Tires	Pneumatic, radial, tubular, 225/75R16						Pneumatic, radial, tubular, with dimensions of 195/R16					
Front/rear suspension	Two longitudinal half-elliptic springs, hydraulic shock absorbers with excess pressure gas						Two longitudinal half-elliptic springs, hydraulic shock absorbers with excess pressure gas, telescopic, double-acting					
STEERING CONTROL												
Steering gear	Integral with steering booster, of "screw – ball nut" type						Integral with steering booster, of "screw – ball nut" type					
Hydraulic power steering pump	Vane-type, double-acting						Vane-type, double-acting					
Steering column	Adjusted by length and tilt angle						Adjusted by length and tilt angle					
BRAKES												
Primary braking system	Two-circuit, with hydraulic drive and vacuum booster						Two-circuit, with hydraulic drive and vacuum booster					
Braking mechanisms	On the front wheels – disc-type, on the rear wheels – drum-type						On the front wheels – disc-type, on the rear wheels – drum-type					
Emergency brake system	Each circuit of the primary braking system						Each circuit of the primary braking system					
Parking brake system	With mechanical cable drive to rear wheels brake gears						With mechanical cable drive to rear wheels brake gears					
ELECTRICAL EQUIPMENT												
Type	Direct current, single-wire, negative terminals of power supply sources and consumers are connected with the body						Direct current, single-wire, negative terminals of power supply sources and consumers are connected with the body					
Rated voltage, V	12						12					
Battery:	6CT-75VL or 6CT-85VL 6CT-66LR						6CT-75VL or 6CT-85VL 6CT-66LR					
– with diesel engine												
– with gasoline engine												

ENGINES

ENGINE	ISF2.8s3129T	ISF2.8s4129p
Emission standard	Euro-3	Euro-4
Engine type	Diesel, with turbine charger and boost intercooler	Diesel, with turbine charger and boost intercooler
Number of cylinders and their arrangement	4, in-line	4, in-line
Cylinder diameter and piston stroke, mm	94x100	94x100
Cylinder capability, l	2.8	2.8
Compression rate	16.5	16.5
Max capacity, kW (hp)	88.3 (120)	88.3 (120)
at crankshaft rotation speed, rpm	3200	3600
Max torque, net, N•m (kg cm)	297 (30.3)	270 (27.5)
at crankshaft rotation speed, rpm	1600-2700	1400-3000
Firing sequence	1-3-4-2	1-3-4-2
Crankshaft rotation speed in the idle mode, rpm:		
— minimum	750 ± 50	750 ± 50
— maximum	3600	4500
Crankshaft rotation direction	Right-hand rotation	Right-hand rotation

SPECIAL VEHICLES

Sobol and GAZelle Business 4WD multi-purpose vehicles with strong off-road capabilities can be used for various types of special machinery, starting with vans and ending with emergency and first aid vehicles and school buses.



GAZ SPORT TEAM

The reliability of off-road GAZ vehicles has been tested in the harsh conditions of rally raid competitions. GAZ Raid Sport team is a two-time winner of the Russian Rally Raid Championship and a participant of the Silk Way rally in 2012, 2013, and 2016.

GAZ racecars are designed on the Sobol 4WD and GAZelle NEXT production vehicles chassis. These sport cars are designed using serially installed assemblies and units such as frame, axles, engines, lockings, springs, and steering mechanisms.

Keep it up!



NOTES
